



CIGNUS[®]

www.cignus.com.ph



CIGNUS CG-2W
NTC Type Acceptance Certificate No.

UHF: ESD - 1613893C
400 - 470MHz



Short Range CG-2W USER'S MANUAL



www.cignus.com.ph

THANK YOU

We are grateful for your choice of our transceiver. We believe that this easy-to-use transceiver will provide dependable and cost-effective communications for you. Our professional two-way radios incorporate the latest in advanced technology and craft. So you will be pleased with the quality and features of our products. Please read this manual carefully to ensure you know how to properly operate the radio before use.

PRECAUTIONS

1. Refer service to qualified technicians only.
2. Do not disassemble or modify the transceiver for any reason.
3. Do not expose the transceiver under direct sunlight long time or to extremely hot condition.
4. Do not place the transceiver on the unstable surface.
5. Keep the transceiver out of dust, moisture, and water.
6. Do not operate the transceiver or charge the battery pack under explosive conditions.

CONTENT

- 01 UNPACKING AND CHECKING EQUIPMENTS
- 01 SUPPLIED ACCESSORIES
- 02 CHARGING THE LI-ION BATTERY PACK
- 03 INSTALLING/REMOVING THE BATTERY PACK
- 04 INSTALLATION OF ACCESSORIES
- 04 INSTALLING THE ANTENNA
- 04 INSTALLING BELT CLIP
- 04 INSTALLING THE (OPTIONAL) SPEAKER/MICROPHONE
- 05 GETTING ACQUAINTED
- 06 OPERATION
- 07 ADDITIONAL FUNCTIONS
- 10 SPECIFICATIONS
- 11 TROUBLESHOOTING

UNPACKING AND CHECKING EQUIPMENTS

Carefully unpack the transceiver. We recommend that you identify the items listed in the following before discarding the packing material. If any items are missing or have been damaged during shipment, please contact your dealers immediately.

ITEM	QUANTITY
Transceiver Unit	1
Antenna	1
Handstrap	1
Charger	1
Battery	1
Beltclip	1
USER'S MANUAL	1

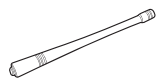

Antenna

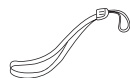

Handstrap

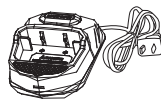

Charger



Battery



Beltclip

CHARGING THE LI-ION BATTERY PACK

Please charge the new battery pack before using it. The new or stored (more than two months) battery pack, which can not reach its full capacity for the first charging. After 2 or 3 times charging and discharging, it can reach full charge.

JUST SEE THE FOLLOWING INSTRUCTIONS

1. Plug the adapter into an electric socket.
2. Insert the transceiver or battery into the drop-in charging tray.
3. Ensure that the battery's contacts connect with the drop-in charging tray properly, while the charging is taking place, the light will glow red.
4. After 3 hours charging, the LED indicator will light green which means the full charge. Now remove the battery or the transceiver from the drop-in charging tray.

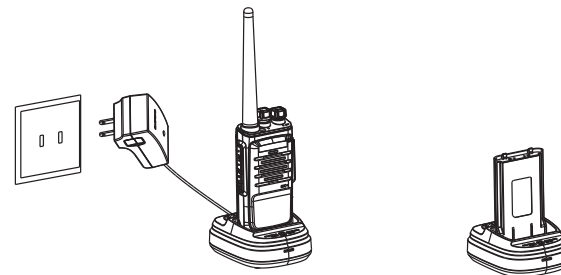

Note:

Do not recharge the battery pack if it is fully charged. Doing so may cause the life of the battery pack to shorten or the battery pack may be damaged.

INSTALLING/REMOVING THE BATTERY PACK

The usage time of JL-11 Battery Pack is about 8 hours, which is based upon 5% transmit/5% receive/90% standby (standard duty cycle). See

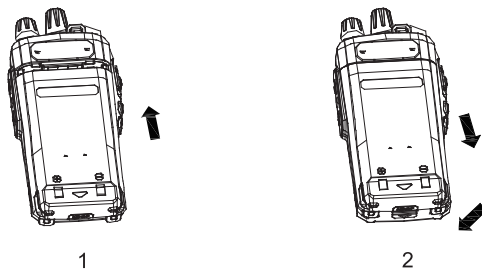

CAUTION:

1. Do not short-circuit the terminals of the battery or throw the battery into the fire.
2. Do not disassemble the battery pack yourself.

INSTALLATION OF ACCESSORIES

INSTALLING THE ANTENNA

Screw the antenna into the connector on the top of the transceiver by holding the antenna at its base and turning it clockwise until secure.

Note:

The antenna is neither a handle, a key ring retainer, nor a speaker, microphone attachment point. Using the antenna in these ways may damage the antenna and degrade your transceiver's performance.

INSTALLING THE BELT CLIP

If the belt clip is not installed, its mounting location may get hot during continuous transmission or under heated environment.

Note:

If the belt clip is not installed, its mounting location may get hot during continuous transmission or under heated environment.

MICRO-HEADSET INSTALLATION OF EXTERNAL

Insert the speaker/microphone plugs into the speaker/microphone jacks of the transceiver.

Note:

The transceiver is not fully water resistant when using speaker/microphone.

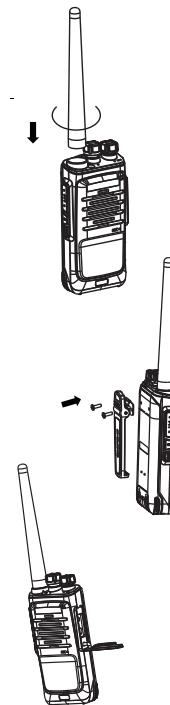

GETTING AC QUAINED

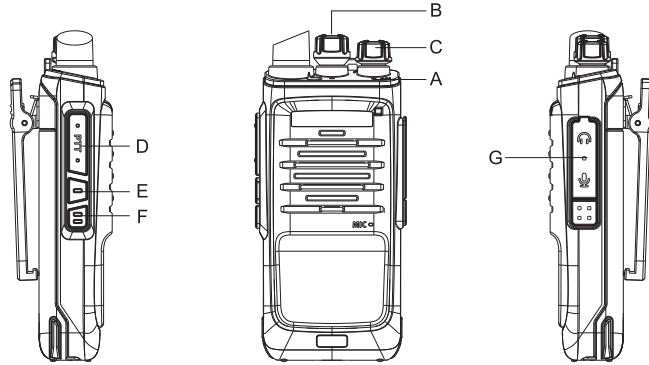

A.Led Indicator— The LED indicator lights continuously red when transmitting. And lights green when in reception condition.

B.Channel Switch—Rotate it to select the channel. No.16 channel is scanning channel.

C.POWER SWITCH/VOLUME CONTROL

Turn clockwise to switch ON the transceiver.

Turn counterclockwise fully to switch OFF the transceiver. Rotate to adjust the volume.

D.PTT (PUSH-TO-TALK) BUTTON

Press this button, then speak into the microphone to call a station.

Release to receive a call.

E.MONITOR BUTTON

Press and hold (Squelch OFF) to hear the background noise;Release to return to normal operation.

F. FUNCTION KEY—Just press to activate the torch function.

G.SPEAKER/MICROPHONE JACKS

OPERATION

SWITCHING POWER ON/OFF

Turn the power switch/volume control clockwise. You will hear a beep and speech, indicating the transceiver is ON.

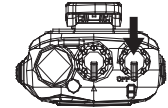

ADJUSTING THE VOLUME

Hold Monitor button down to listen to audio level while rotating the Power switch/Volume control. Rotate clockwise to increase and counterclockwise to decrease volume.

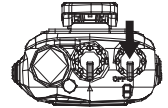

SELECTING THE CHANNEL

Turn the channel switch to select your desired channel. NO.16 is Scanning Channel.

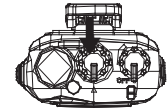

TRANSMITTING

To transmit, press and hold [PTT] and speak into the microphone in your normal tone of voice.

The LED indicator lights continuously red when transmitting. To maximize sound clarity at the receiving station, hold the transceiver 2 to 3 inches from mouth and talk in normal tone of voice.

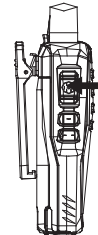

ADDITIONAL FUNCTIONS

SQUELCH LEVEL

The purpose of Squelch is to mute the speaker when no signals are present (Squelch OFF). With the squelch level correctly set, you will hear sound only while actually receiving signals (Squelch ON). The squelch level can be adjusted via program software.

TIME-OUT TIMER (TOT)

The purpose of the Time-out Timer is to prevent any caller from using a channel for an extended period of time which will cause thermal damage. The built-in Time-out Timer limits each transmission time to a certain time. The transmission time extends the certain time you set, an alert tone will sound.

SCAN

Scan is a useful function for hands-off monitoring of your favorite frequencies. When transceiver is set as SCAN via software, turn the channel selector to channel 16, the transceiver will automatically detect the activities of scanning channel from 1 to 15 (Different channel can be set) .

- 1.The transceiver stops scanning at the frequency (or memory channel) where a signal is detected. It then continues or stops scanning.
- 2.If there are less than 2 channels, it can not scan.
- 3.On channel 16, press PTT and MONI key, it will turn on the SCAN,or turn off the SCAN.
- 4.If the FM radio function is activated, it can not scan.

VOICE PROMPT

- 1.Voice Prompt ON/OFF can be set via software.
- 2.On channel 10, press PTT and MONI key, then switch on the transceiver, Voice Prompt can be cancelled or activated.
- 3.On channel 15, press PTT and MONI key, then switch on the transceiver to choose different voice prompt languages.

VOX(Voice Operated Transmission)

VOX eliminates the necessity of manually switching to the transmission Mode each time you want to transmit. The transceiver automatically switches to Transmission Mode when the VOX circuitry senses that you have begun speaking into the microphone.When you operate the VOX function, you must use an optional headset with microphone.

- 1.When operating the VOX function, be sure to set the VOX Gain level which allows the transceiver to recognize the sound levels.
- 2.If the microphone is too sensitive, the transceiver will begin transmitting when there is noise in the background.
- 3.If it is not sensitive enough, it will not pick up your voice when you begin speaking. Be sure to adjust the VOX Gain level to an appropriate sensitivity to allow smooth transmission.On channel 1-5, press and hold the MONI and PTT, then switch on the transceiver, thus to activate the VOX functions ON/OFF.

EMERGENCY ALARM

On channel 11, press and hold the PTT and MONI, then switch the transceiver on, thus to activate the emergency alarm function ON/OFF. Also it can be set with program software. If the function is OFF, the other transceiver receives the signal, it is not able to alarm.

Battery Saver

The battery saver function will decrease the amount of power used when a signal is not being received and no operations are being performed(no keys are being pressed, and no switches are being tuned).While the channel is not busy and no operation is performed for more than 10 seconds, Battery Saver turns ON.When a signal is received or an operation is performed, Battery Saver turns OFF.

BATTERY LOW ALERT

Battery Low Alert reminds you of recharging. When the battery power is very low, an alert tone will sound and the LED indicator will blink red. Please recharge or replace the battery pack.

MONITOR

When you are receiving and no signals present, the squelch function can mute the speaker, so you can not hear the background noise. If you want to switch the squelch function OFF, press and hold [MONI] button. It is very helpful when you want to adjust the volume level and receive the weak signals.

BUSY CHANNEL LOCK-OUT (BCL)

Busy Channel Lock-out function can be turned ON/OFF with program software on every channel. When activated, BCL prevents you from interfering with other parties who may be using the same channel that you selected. Pressing the PTT switch while the channel is in use will cause your transceiver to emit an alert tone and transmission will be inhibited (you cannot transmit). Release the PTT switch to stop the tone and return to receive mode.

CTCSS/DCS

CTCSS (Continuous Tone Coded Squelch System)/ (Digital Coded Squelch) You may sometimes want to hear calls from only specific persons or groups. In this case, use the selective call which allows You to ignore unwanted calls from other persons who are using the same frequency. CTCSS or DCS is a sub-audible tone and is selectable from among the 39 or 83 tone frequency listed.

NOTE:

CTCSS and DCS do not cause your conversation to be private and scrambled. It only relieves you from listening to unwanted conversations.

SPECIFICATION

Frequency Range	400-470MHz
Channel Capacity	16
Dimensions	125mmx56.8mmx32mm
Weight	150g

NOTE:

All specifications are subject to change without notice.

TROUBLESHOOTING GUIDE

TROUBLES	GUIDE
No Power	Check battery installation and/or replace batteries.Voltage Capacity Quickly Go Out. The battery life is over, replace new one.
Couldn't I communicate with other group members.	First, please verify that the channel frequency and the CTCSS you are using are the same as those of your group members. If the channel frequency and the CTCSS are the same, please verify that your group members are within the radio coverage
Hear the voice from other groups.	Please change your CTCSS for the channel. At the same time, you also need to the CTCSS for all the radios in your group. If you don't like this, you may apply another channel frequency.
Why can I hear the voices clearly from other group, sometimes, my voice is intermittent.	Please check whether the MIC is blocked by something. If so, Please return the radio to your authorized dealer for maintenance. Sometimes, your frequency is same as the frequency of other groups.
Can't turn on the radio and even it is turned on, it often shuts off automatically.	Please check the battery contacts on the radio. If it is broken or twisted, please return the radio to your authorized dealer for maintenance



WARRANTY CARD

Model:

Serial NO.:

Dealer:

User name:

Address:

Purchase Date:

Tel NO.:

Fax NO.:

Zip Code:

Warranty Remarks:

- 1.The consumer keeps the warranty card as the proof for repairing.
- 2.The card is of validity with the stamp and date.
- 3.The card mustn't be altered. Please confirm that the card NO. and the machine NO. must be same, or else it is not valid.
- 4.The accessories, such as charger, battery, earphone, antenna, and program cable are not covered. The dealer will repair or replace any defective parts during one year limited warranty period.
- 5.The consumer can send the machine to the purchase site or our maintenance sites for repairing.